



**Document for Tender**  
**No. (57/2022)**  
**(53 Pages)**

**Supply of:**

- 36 KV, gray color silicon rubber post line insulators complete with horizontal trunnion clamps and total length (530 ±5) mm.
- 36 KV, gray color silicon rubber composite tension insulators with total length (615 ±5) mm.
- 36 KV, gray color silicon rubber composite tension insulators with total length (525 ±5) mm.

**Tenderer:**

- Name: .....
- Address: .....
- Telephone / Cellular: .....
- Fax: .....
- Website: .....
- E-Mail: .....
- Contact Person: .....

Tender summary mentioned in page (4-7) shall be fill by the tenderer, otherwise his tender will not be considered.

**Tender Document Cost = 125 JD.**



# List of Contents

Table No.1

<b>No.</b>	<b>Description</b>	<b>Page</b>
<b>1</b>	Cover Page	<b>1</b>
<b>2</b>	List of Contents	<b>2</b>
<b>3</b>	Invitation to Tender	<b>3</b>
<b>4</b>	Tender summary form	<b>4-7</b>
<b>5</b>	General Conditions	<b>8-17</b>
<b>6</b>	Tendering Instructions	<b>18-21</b>
<b>7</b>	General requirements	<b>22-25</b>
<b>8</b>	Inspection and Testing	<b>26-27</b>
<b>9</b>	Form of Bid Bond	<b>28</b>
<b>10</b>	Form of Performance Bond	<b>29</b>
<b>11</b>	Technical specifications	<b>30-36</b>
<b>12</b>	Drawings	<b>37-40</b>
<b>13</b>	Schedule No.1 &No.2&No.3	<b>41-46</b>
<b>14</b>	Special Requirements	<b>47</b>
<b>15</b>	Departures from Specification	<b>48</b>
<b>16</b>	Program for Manufacture and Delivery	<b>49</b>
<b>17</b>	Manufacturing and Places of manufacture and Testing	<b>49</b>
<b>18</b>	Delivery Schedule	<b>50</b>
<b>19</b>	Price Summary and Delivery Periods	<b>51</b>
<b>20</b>	Inspection details	<b>52</b>
<b>21</b>	Main Offer Details	<b>52</b>
<b>22</b>	Tender Agreement Summary	<b>53</b>

## Invitation to Tender

**No. (57/2022)**

Dear Sir;

You are kindly requested to tender for the supply of the below mentioned materials as per the quantities and technical specifications enclosed herewith, by filling in the schedules, signing the form of tender, and forward the complete tender documents to the attention of **IDECO - Director General** addressed as seen on the cover page, to be received not later than 2 pm (local time) due **July 20, 2022.**

All bids must be accompanied with a Bid Bond of a value not less than 5% of the highest alternative tender price, otherwise your tender will not be considered. The bid bond shall be enclosed in the same envelope of the tender and must be delivered to tenders secretary office located in **Tender's Secretary Office Located In Southern Station – Supplies Department- Tenders Section** - not later than 2 pm (local time) due **July 20, 2022.**

**Table No.2**

Item	Quantity (pcs)	Material Description	Stock Code
1	15,000	36 KV, gray color silicon rubber post line insulators complete with horizontal trunnion clamps suitable with conductor size (50-200) mm <sup>2</sup> end and base fittings with zinc sleeve, and total length ( 530 ±5) mm.	5970-1366
2	4,000	36 KV, gray color silicon rubber composite tension insulators complete with end and base fittings coupling shall be socket eye and ball eye 16 B with zinc sleeve , and total length ( 615 ±5) mm.	5970-1385
3	5,000	36 KV, gray color silicon rubber composite tension insulators complete with end and base fittings coupling shall be socket eye and ball eye 16 B with zinc sleeve and total length ( 525 ±5) mm.	5970-1386

**Tender Summary for Tender No. 57/2022**

**These 4 pages must be completely filled out by the bidder; otherwise it may be a reason for exclusion from the bidding competition:**

<b>Name of bidder:</b>		
<b>Address:</b>		
<b>Telephone/Cellular/Fax</b>		
<b>E- Mail</b>		
<b>Contact Person:</b>		
<b>Name of the manufacturer and country of origin:</b>		
<b>The value of the bid bond and the bank issued from:</b>		
<b>The total value of the bid:</b>	<b>Currency</b>	
	<b>Total price</b>	<b>Including tax &amp; fees</b>
		<b>Exclude tax &amp; fees exempt</b>
	<b>Total price in writing</b>	
<b>Delivery</b>	<b>Ex-works delivery</b>	
	<b>Aqaba port delivery</b>	
	<b>Idecostores delivery</b>	
<b>Testing</b>	<b>Place of manufacturing</b>	
	<b>Place of testing</b>	
<b>Cost for inspection &amp; testing:</b>		

Official signature and seal / Bidder

Irbid Electricity Company Use:

Chairman of the Committee

Deputy Chairman of the Committee

Committee member

Committee member

Committee member

Committee member

Committee member

**Departures**

<b>Departures from</b>	<b>Technical specifications</b>	<b>Required</b>	<b>offered</b>
	<b>Special requirements</b>	<b>Required</b>	<b>offered</b>

**Official signature and seal / Bidder**

**Irbid Electricity Company Use:**

**Chairman of the Committee**

**Deputy Chairman of the Committee**

**Committee member**

**Committee member**

**Committee member**

**Committee member**

**Committee member**

- 1- **General Condition**: We committed to implementing all items mentioned in the general conditions within the bid document number (     ), and the subcategories of these items.
- 2- **Tendering Instructions**: We committed to implementing all items mentioned in the tendering instructions within the bid document number (     ), and the subcategories of these items.
- 3- **General Requirement (Standards and Regulation)** : We committed to implementing all items mentioned in the general conditions within the bid document number (     ), , and the subcategories of these items.
- 4- **Inspection and testing**: We committed to implementing all items mentioned in the inspection and testing within the bid document number (     ), and the subcategories of these items.
- 5- **Special Requirements**: We committed to implementing all items mentioned in the special requirements within the bid document number (     ), and the subcategories of these items.
- 6- We committed to fill out all the required pages with the bid documents, without any discrepancies with similar information contained in the Tender Summary.
- 7- We committed that in case there is a difference in the prices provided by us, the lower price will be approval.
- 8- Based on the above we sign.

**Official signature and seal / Bidder**

<b><u>Irbid Electricity Company Use:</u></b>
--

**Chairman of the Committee**

**Deputy Chairman of the Committee**

**Committee member**

**Committee member**

**Committee member**

**Committee member**

**Committee member**

**In case there are any comments or additional terms or other offers by the bidder; it must be mentioned or Brief about it in the summary of this page:**

**Official signature and seal / Bidder**

**Irbid Electricity Company Use:**

**Chairman of the Committee**

**Deputy Chairman of the Committee**

**Committee member**

**Committee member**

**Committee member**

**Committee member**

**Committee member**

# GENERAL CONDITIONS

- The below are general conditions of contract for the supply and delivery of plant and materials based on United Nations economic commission for Europe publication ref.: me/ 188 Geneva. March, 1953.

## 1. Preamble

1.1. These General Conditions shall apply, save as varied by express agreement accepted in writing by both parties.

### 1.2. Definition of Terms:

The "Purchaser" shall mean "Irbid District Electricity Co. Ltd." Hereinafter called "IDECO", and shall include IDECO's legal personal representatives and duly appointed engineers. The "Engineer" shall mean "Irbid District Electricity Co." or persons for the time being or from time to time duly appointed in writing by the purchaser to act as Engineer or the purpose of the contract.

The words "approved" and "approval" where used in these conditions or in the specification shall mean "approved by" and "approval of" the purchaser respectively. The "Vendor" shall mean the "Contractor" whose tender has been accepted by the purchaser and shall include the Vendor's. (Contractor's) legal personal representatives, successors and permitted assigns, "F.O.B. Price" shall mean the cost of the equipment delivered free on board the ship or truck or aircraft, all port charges and handling charges (also heavy lift if applicable) included.

The contractor must insure the material against all risks from the time it leaves the works until it is placed F.O.B "C&F price" shall mean F.O.B. price plus freight including unloading at the port of destination. All Marine Insurance will be effected by the purchaser. The contractor must provide full details of the material to be shipped in good time for IDECO to arrange for Marine Insurance before the material is actually shipped.

## 2. Formation of Contract

2.1. The contract shall be deemed to have been entered into when the purchaser has sent an acceptance in writing before the time set in the tender for acceptance or any such later date extended by the tenderer at the request of the purchaser.

2.2. Notwithstanding that the contract and correspondence in connection with the contract shall be in the English language, the contract shall be and be deemed to be a Jordan contract and shall accordingly be governed by and construed according to the laws for the time being in force in the Hashemite Kingdom of Jordan.

2.3. **Power to Vary The Work:** alternations, amendments, omissions, additions, suspensions, or variations of the work, (hereinafter referred to as "variations") under the contract as shown by the contract drawings or the specification shall be made by the contractor except as directed in writing by the purchaser, but the purchaser shall have full power, subject to the provision hereinafter contained, from time to time during the execution of the contract by notice in writing to instruct the contractor to make such variation without prejudice to the contract and the contractor shall carry out such variations, and be bound by the same conditions, as far as applicable, as though the said variations occurred in the specification. If any suggested variations would, in the opinion of the contractor, if carried out, prevent him fulfilling any of his obligations or guarantees under the contract, he shall notify the purchaser thereof in writing, and the purchaser shall decide forthwith whether or



not the same shall be carried out, and if the purchaser confirms his instructions, the contractor's obligations and guarantee shall be modified to such an extent as may be justified. The difference in cost, if any, occasioned by any such variations, shall be added to or deducted from the contract price as the case may require. The amount of such difference, if any, shall be ascertained and determined in accordance with the rates specified in the schedule of prices so far as the same may be applicable, and **where the rates are not contained in the said Schedule, or are not applicable they shall be settled by the purchaser and the contractor jointly. But the purchaser shall not become liable for the payment of any charge in respect of any such variations, unless the instruction for the performance of the same shall have been given in writing by him. In the event of the purchaser requiring any variation, such reasonable a proper notice shall be given to the contractor as will enable him to make his arrangements accordingly, and in cases where goods or materials are already prepared, or any designs, drawings, or patterns made or work done that requires to be altered a reasonable sum in respect thereof shall be allowed by the purchaser. Provided that no such variations shall, except with consent in writing of the contractor, be such as will involve an increase or decrease of the total price payable under the contract by more than 25 percent thereof. The power given to the purchaser to make any alteration, amendment, omission, addition or variation to, from or in any part of the works shall include power to vary from time to time the date for the completion of the works or any part thereof, also the purchaser shall have the absolute right to increase the quantities in such manner that the increment does not exceed the amount of 25% of the total price payable under the contract, however; the same prices awarded and any other relevant conditions shall remain the same for this purpose. This right is valid during the tender validity and within 120 days from the date of the order letter, and during delivery period.**

**2.4. Precedence:** In the event of any discrepancy or contradiction between the provisions of the conditions of contract and of the specification, the conditions of contract shall take precedence.

**2.5. Prices:** The Tender calls for **firm prices**.

### **3. Drawings and Descriptive Documents**

**3.1.** The weights, dimensions, capacities, prices, performance rating and other data included in catalogues, prospectuses, circulars, advertisement, illustrated matter and price lists constitute an approximate guide. These data shall not be binding save to the extent that they are by reference expressly included in the contract.

**3.2.** Any drawings or technical documents intended for use in the construction of the material or of part thereof and submitted to the purchaser prior or subsequent to the formation of the contract remain the exclusive property of the Vendor. They may not, without the Vendor's consent, be utilized by the purchaser or copied, reproduced, transmitted or communicated to a third party. Provided, however, that the said plans and documents shall be the property of the purchaser.

**a.** If it is expressly so agreed, or

**b.** If they are referable to a separate preliminary development contract on which no actual construction was to be performed and in which the property of the Vendor in the said plans and documents was not reserved.

**3.3.** Any drawings or technical documents intended for use in the construction of the material or of part thereof and submitted to the Vendor by the Purchaser prior or subsequent to the formation of the contract remain the exclusive property of the Purchaser. They may not,

without his consent be utilized by the Vendor or copied, or reproduced, transmitted or communicated to a third party.

**3.4.** The Vendor shall, if required by the purchaser, furnish free of charge to the purchaser at the commencement of the Guarantee Period, as defined in clause 9, information and drawings other than manufacturing drawings of the material in sufficient detail to enable the purchaser to carry out the erection, commissioning, operation and maintenance (including running repairs) of all parts of the material. Such information and drawings shall be the property of the purchaser and the restrictions on their use set out in paragraph 2 hereof shall not apply thereto. Provided that if the Vendor so stipulates, they shall remain confidential.

#### **4. Materials Packing and Shipping Marks**

All materials, equipment and goods shall be very well packed, in seaworthy containers and/or wooden cases, etc. These should protect the material during shipping, handling, unloading, and for a reasonable period of storage at Aqaba and latter storage at IDECO stores. Packing for indoor materials should be done in such manner as to adequately ensure no ingress of moisture during the shipping and storage periods. Packing of fragile equipment (e.g. including instruments and porcelain) should be done in a way which ensures a reasonable resistance to impact breakage during transport. Packing shall in general be adequate and in compliance with the best international practice. A descriptive and fully itemized list shall be prepared for the contents of each packing case. A copy of this list shall be placed in a waterproof envelope under a metal or other suitable plate securely fastened to the outside of one end of the case. And its position adequately indicated by stenciling on the case. Where appropriate drawing showing the erection marking of the items concerned shall be placed inside the case, IDECO will supply the successful tenderer with a drawing of its shipping mark for utilization. All packing cases, crates, barrels and drums shall remain the property of the purchaser.

#### **5. Inspection and Testing**

**5.1.** If expressly agreed in the contract, the purchaser shall be entitled to have the quality of the materials used and the parts of the instruments, both during manufacture and when completed, inspected and checked by his authorized representatives. Such inspection and checking shall be carried out at the place of manufacture during normal working hours after agreement with the Vendor as to date and time.

**5.2.** If as a result of such inspection and checking the purchaser shall be of the opinion that any materials or parts are defective or not in accordance with the contract, he shall state in writing his objections and the reasons therefore.

**5.3. TESTS:** Acceptance tests will be carried out and, unless otherwise agreed, will be made at the Vendor's works and during normal working hours. If the technical requirements of the tests are not specified in the contract, the tests will be carried out in accordance with the general practice obtaining in the appropriate branch of the industry in the country where the material is manufactured.

**5.4.** The Vendor shall give to the purchaser sufficient notice of the tests to permit the purchaser's representatives to attend. If the purchaser is not represented at the tests, the tests report shall be communicated by the Vendor to the purchaser and shall be accepted as accurate by the purchaser.

- 5.5. If on any test (other than a test site, where test on site are provided for in the contract) the material shall be found to be defective or not in accordance with the contract, the Vendor shall with all speed make good the defect or ensure that the plant complies with the contract. Thereafter, if the purchaser so requires, the test shall be repeated.
- 5.6. Unless otherwise agreed, the Vendor shall bear all the expenses of tests carried out in his works.
- 5.7. If the contract provides for tests on site, the terms and conditions governing such tests shall be such as may be specially agreed between the parties.

## 6. Passing of Risk

Save as provided in paragraph 7.6, the time at which the risk shall pass shall be fixed in accordance with the International Rules for the Interpretation of Trade Terms (Incoterms) of the International Chamber of Commerce in force at the date of the formation of the contract.

## 7. Delivery:

- 7.1. Unless otherwise agreed the delivery period shall run from the latest of the following dates:
- a. The date of the formation of the contract as defined in clause 2.
  - b. The date on which the Vendor receives notice of the issue of a valid import license where such is necessary for the execution of the contract.
  - c. The date of the receipt by the Vendor of such payment in advance of manufacture as stipulated in the contract.
- 7.2. Should delay in delivery be caused by any of the circumstances mentioned in clause 10 or by an act or omission of the purchaser and whether such cause occur before or after the time or extended time for delivery, there shall be granted subject to the provisions of paragraph 5 hereof such extension of the delivery period as is reasonable having regard to all the circumstances of the case.
- 7.3. If a fixed time for delivery is provided for in the contract and the Vendor fails to deliver within such time or any extension thereof granted under paragraph 2 hereof, the purchaser shall be entitled, on giving to the Vendor within a reasonable time notice in writing, to claim a deduction of the price payable under the contract. Such deduction shall be calculated at the rate of one half of one percent of that part of the price payable under the contract which is properly attributable to such portion of the plant as cannot in consequence of the said failure be put to the use intended for each complete week of delay commencing on the due date of delivery, but shall not exceed a maximum percentage deduction of ten percent. Such deduction shall be allowed when a payment becomes due on or after delivery. Save as provided in paragraph 5 hereof, such deduction of price shall be to the exclusion of any other remedy of the purchaser in respect of the Vendor's failure to deliver as aforesaid. **((In case the required material shall be delivered in number of shipments, then the maximum percentage deduction of ten percent shall be applied on amount of each shipment)).**
- 7.4. If the time for delivery mentioned in the contract is an estimate only, either party may after the expiration of two thirds of such estimated time require the other party in writing to agree a fixed time. Where no time for delivery is mentioned in the contract, this course shall be open to either party after the expiration of six months from the formation of the contract. If in either case the parties fail to agree, either party may have recourse to arbitration, in accordance with the provisions of clause 13, to determine a reasonable time for delivery and the time so determined shall be deemed to be the fixed time for delivery

provided for in the contract and paragraph 3 hereof shall apply accordingly.

**7.5.** If any portion of material in respect of which the purchaser has become entitled to the maximum deduction provided for by paragraph 3 hereof, or in respect of which he would have been so entitled had he given the notice referred to therein, remains undelivered, the purchaser may by notice in writing to the Vendor require him to deliver and by such last mentioned notice fix a final time for delivery which shall be reasonable taking into account such delay as has already occurred. If for any reason whatever the Vendor fails within such time to do everything that he must do to effect delivery, the purchaser shall be entitled by notice in writing to the Vendor, and without requiring the consent of any court, to terminate the contract in respect of such portion of the material and thereupon to recover from the Vendor any amount not exceeding that part of the price payable under the Contract which is properly attributable to such portion of the material as could not in consequence of the Vendor's failure be put to the use intended.

**7.6.** If the purchaser fails to accept delivery on due date, he shall nevertheless make any payment conditional on delivery as if the material had been delivered. The Vendor shall arrange for the storage of the material at the risk and cost of the purchaser. If required by the purchaser, the Vendor shall insure the material at the cost of the purchaser. Provided that if the delay in accepting delivery is due to one of the circumstances mentioned in clause 10 and the Vendor is in a position to store it in his premises without prejudice to his business, the cost of storing the material shall not be borne by the purchaser.

**7.7.** Unless the failure of the purchaser is due to any of the circumstances mentioned in clause 10, the Vendor may require the purchaser by notice in writing to accept delivery within reasonable time. If the purchaser fails for any reason whatever to do so within such time, the Vendor shall be entitled by notice in writing to the purchaser, and without requiring the consent of any court, to terminate the contract in respect of such portion of the material as is by reason of the failure of the purchaser aforesaid not delivered and thereupon to recover from the purchaser any loss, suffered by reason of such failure up to an amount not exceeding the value of the material, the delivery of which has not been accepted.

## **8. Force Majeure**

**8.1.** Notwithstanding the provisions of clauses 7, the supplier shall not be liable for forfeiture of its performance security, liquidated damages or termination for default, if and to the extent that, its delay in performance or other failure to perform its obligations under the contract is the result of an event of Force Majeure.

**8.2.** For purposes of this clause, "Force Majeure" means an event beyond the control of the supplier not involving the supplier's fault or negligence. Such events may include, but are not restricted to, acts of God, acts of the purchaser either in its sovereign or contractual capacity, wars or revolutions, fires, floods, epidemics, quarantine restrictions and freight embargoes.

**8.3.** If a Force Majeure situation arises, the supplier shall promptly notify the purchaser in writing of such condition and the cause thereof. Unless otherwise directed by the purchaser in writing, the supplier shall continue to perform its obligations under the contract as far as is reasonably practical, and shall employ all reasonable alternative means for performance not prevented by the Force Majeure event.

## **8.4. Payment:**

### **8.4.1 Terms of Payment:**

- 1. The company prefers to deal with the supplier on an open account basis, and the payment to be made as the following:**

- a. The supplier has to send the following documents (Invoice origin + five copies), (Certificate of origin + five copies), (Bill of lading 3-negotiable + 5 non-negotiable), (Test certificate (where applicable) + 6 copies) to IDECO company/ financial department, and the document shall be legalized for shipping purposes.
    - b. 100% of the invoice value to be paid within 30 days of (Receipt of IDECO acceptance certificate, Receipt of goods at IDECO stores).
    - c. Payment will be released on first week of each month.
  2. In case the supplier insists on L/C as a method of payment, all/LC charges will be borne by the supplier and charge to his own account and the terms will be as follows:
    - a. The L/C will be confirmed and irrevocable but has to be acceptance L/C and the supplier has to send the following documents: (Invoice origin + five copies), (Certificate of origin + five copies), (Bill of lading 3-negotiable + 5 non-negotiable), (Test certificate (where applicable) + 6 copies), and the document shall be legalized for shipping purposes.
    - b. Payment will be released after submitting IDECO's acceptance certificate to the bank within 30 days after receipt of goods at IDECO's stores.
    - c. Payment will be released on first week of each month.
- 8.4.2 Currency of Payment:** The contract price will normally be paid in the currency or currencies in which the price has been stated. The purchaser, however, reserves the right to make payments in the currencies of the countries of origin of goods and services at the exchange rates applicable at the time of payment of the contract price.
- 8.4.3** Any advance payments made by the purchaser are payments on account and do not constitute a deposit, the abandonment of which would entitle either party to terminate the contract.
- 8.4.4** If delivery has been made before payment of the whole sum payable under the contract, material delivered shall, to the extent permitted by the law of the country where the plant is situated after delivery, remain the property of the Vendor until such payment has been effected. If such law does not permit the Vendor to retain the property in the material, the Vendor shall be entitled to the benefit of such other rights in respect thereof as such law permits him to retain. The purchaser shall give the Vendor any assistance in taking any measures required to protect the Vendor's right of proper or such other rights as aforesaid.
- 8.4.5** A payment conditional on the fulfillment of an obligation by the Vendor shall not be due until such obligation has been fulfilled, unless the failure of the purchaser is due to an act or omission of the purchaser.
- 8.4.6** If the purchaser delays in making any payment, the Vendor may postpone the fulfillment of his own obligations until such payment is made, unless the failure of the purchaser is due to an act or omission of the Vendor.

**8.4.7** If delay by the purchaser in making any payment is due to one of the circumstances mentioned in clause 10, the Vendor shall not be entitled to any interest on the sum due.

**8.4.8** Save as aforesaid, if the purchaser delays in making any payment, the Vendor shall on giving to purchaser within a reasonable time notice in writing be entitled, and without requiring the consent of any court, to terminate the contract and thereupon to recover from the purchaser the amount of his loss up to the value of the material, the payment for which has been unreasonably delayed.

## **9. Guarantee:**

**9.1.** Subject as hereinafter set out; the Vendor undertakes to remedy any defect resulting from faulty design, materials or workmanship.

**9.2.** This liability is limited to defects which appear during the period (hereinafter called the Guarantee Period) of fifteen months from date of dispatch ex-works or twelve months from the date of setting to work whichever shall be the later.

**9.3.** In fixing this period due account has been taken of the time normally required for transport as contemplated in the contract.

**9.4.** In respect of such parts (whether of the Vendor's own manufacture or not) of the material as are expressly mentioned in the contract, the Guarantee Period shall be such other period (if any) as is specified in respect of each of such parts.

**9.5.** The Guarantee period shall start from the later of the dates mentioned in paragraph 2 above. If, however dispatch ex-works is delayed for a period in excess of three months due to a cause beyond the control of the Vendor the Guarantee Period shall not extend beyond eighteen months from the date the material was ready for dispatch ex-works.

**9.6.** The Guarantee period is based on the continuous use of the material in service for 24 hours every day.

**9.7.** A fresh Guarantee Period equal to that stated in paragraph 2 hereof shall apply, under the same terms and conditions as those applicable to the original material, to parts supplied in replacement of defective parts or to parts renewed in pursuance of this clause. This provision shall not apply to the remaining parts of material, the Guarantee Period of which shall be extended only by a period equal to the period during which the material is out of action as result of a defect covered by this clause.

**9.8.** In order to be able to avail himself of his rights under this clause the purchaser shall notify the Vendor in writing without delay of any defects that have appeared and shall give him every opportunity of inspecting and remedying them.

**9.9.** On receipt of such notification the Vendor shall remedy the defect forthwith and at his own expense. Save where the nature of the defect is such that it is appropriate to effect repairs on site, the purchaser shall return to the Vendor any part in which a defect covered by this clause has appeared, for repair or replacement by the Vendor, and in such case the delivery to the purchaser of such part properly repaired or a part in replacement thereof shall be deemed to be a fulfillment by the Vendor of his obligations under this paragraph in respect of such defective part.

**9.10.** The Vendor shall bear all the costs and risks of the transport of defective parts or equipment and their replacements.

- 9.11.**Where, in pursuance of paragraph 9 hereof, repairs are required to be effected on site, the conditions covering the attendance of the Vendor's representatives on site shall be such as may be specially agreed between the parties.
- 9.12.**Defective parts replaced according to this clause shall be placed at the disposal of the Vendor.
- 9.13.**If the Vendor refuses to fulfill his obligations under this clause or fails to proceed with due diligence after being required so to do, the purchaser may proceed to do the necessary work at the Vendor's risk and expense, provided that he does so in a reasonable manner.
- 9.14.**The Vendor's liability does not apply to defects arising out of materials provided, or out of a design stipulated, by the purchaser.
- 9.15.**The Vendor's liability shall apply only to defect that appears under the conditions of operation provided for by the contract and under proper use. It does not cover defects due to causes arising after the risk in the material has passed in accordance with clause 6. In particular, it does not cover defects arising from the purchaser's faulty maintenance or erection, or from alterations carried out without the Vendor's consent in writing, or from repairs carried out improperly by the purchaser, nor does it cover normal deterioration.
- 9.16.**Save as in this clause expresses, the Vendor shall be under no liability in respect of defects after the risk in the material has passed in accordance with clause 6, even if such defects are due to causes existing before the risk so passed. It is expressly agreed that the purchaser shall have no claim in respect of personal injury or of damage to property not the subject matter of the contract or of loss of profit unless it is shown from the circumstances of the case that the Vendor has been guilty of gross misconduct.
- 9.17.**The vendor is required to transport all the defective or not in accordance materials, from our stores within a month from date of notification. All costs and expenses of transportation shall be borne by the vendor. Unless otherwise agreed. IDECO has the right to deal with the defective materials in a proper way.
- 9.18.**Gross misconduct "does not comprise any and every lack of proper care or skill, but means an act or omission on the part of the Vendor implying either a failure to pay due regard to serious consequences which a conscientious contractor would normally foresee as likely to ensue, or a deliberate disregard of any consequences of such act or omission.
- 10. Relief:**
- 10.1.**The following shall be considered as cases of relief if they intervene after the formation of the contract and impede its performance: industrial disputes, and any other circumstances (e.g. fire, mobilization, requisition, embargo, currency restrictions, insurrection, shortage of transport, general shortage of materials and restrictions in the use of power) when such other circumstances are beyond the control of the parties.
- 10.2.**The party wishing to claim relief by reason of any of the said circumstances shall notify the other party in writing without delay on the intervention and on the cessation thereof.
- 10.3.**The effects of the said circumstances so far as they affect the timely performance of their obligation by the parties, are defined in clauses 7 and 8. Save as provided in paragraph 7.5, 7.7, and 8.7, if by reason of any of the said circumstances, the performance of the contract within a reasonable time becomes impossible, either party shall be entitled to terminate the contract by notice in writing to the other part without requiring the consent of any court.
- 10.4.**If the contract is terminated in accordance with paragraph 3 hereof, the division of the

expenses incurred in respect of the contract shall be determined by agreement between the parties.

**10.5.** In default of agreement it shall be determined by the arbitrator which party has been prevented from performing his obligations and that party shall bear the whole of the said expenses. Where the purchaser is required to bear the whole of the expenses and has before termination of the contract paid to the Vendor more than the amount of the Vendor's expenses, the purchaser shall be entitled to recover the excess. If the arbitrator determines that both parties have been prevented from performing their obligation, he shall apportion the said expenses between the parties in such manner as to him seems fair and reasonable, having regard to all the circumstances of the case.

**10.6.** For the purposes of this clause "expenses" means actual out of pocket expenses reasonably incurred, after both parties shall have mitigated their losses as far as possible. Provided that as respects material delivered to the purchaser the Vendor's expenses shall be deemed to be that part of the price payable under the contract which is properly attributable thereto.

**11. Limitation of Damages:**

**11.1.** Where either party is liable in damages to the other these shall not exceed the damage which the party in default could reasonably have foreseen at the time of the formation of the contract.

**11.2.** The party who sets up a breach of the contract shall be under a duty to take all necessary measures to mitigate the loss which has occurred provided that he can do so without unreasonable inconvenience or cost. Should he fail to do so, the party guilty of the breach may claim a reduction in the damages.

**12. Rights at Termination:** Termination of the contract from whatever cause arising shall be without prejudice to the rights of the parties accrued under the contract up to the time of termination.

**13. Arbitration and Law Applicable:**

**13.1.** Any dispute, question or controversy shall arise between the purchaser and the contractor concerning this contract the matter in dispute shall be referred to an arbitration committee composed of three (3) arbitrators. One arbitrator shall be nominated by the purchaser and one by the contractor, and the third arbitrator shall be appointed by both parties. If either party fails to appoint his arbitrator within one month of the appointment of the arbitrator by the other party, or if the two parties fail to agree on the third arbitrator within two months of the date of the request to refer the dispute to arbitration, such arbitrator shall be appointed by the president of the highest court in Jordan at the request of either or both parties.

**13.2.** The decision of the arbitrators shall be final and binding on both the purchaser and the contractor. Any such reference shall conform to the statutory enactment or regulation governing arbitration as may be in force in Jordan at the time. The assessment of costs incidental to the reference and award respectively shall be at the discretion of the arbitration committee.

**14. After Awarding Tenders, winner tenderer will be assessment according to quality of good, delivery period, service after sale, and assessment weight will be considered in coming tenders' evaluation.**

**15.** Where the contractor, who was awarded the bid, ceased or failed in implementing the conditions of the bid; IDECO Company has the right to take the appropriate decision on the confiscation of the amount of guarantee or insurance provided by the bidder upon his participation in the tender, in addition, IDECO has the right to the restriction of participation of this bidder in all of the company's bids for the duration seen appropriate.



- 16.** The purchaser has the complete right to reply on contractor's clarifications during 7 days, and during this period there is not exemption from incurred penalty for the event.
- 17.** The Irbid Electricity Company shall be entitled to penalize the contractor (late to supply the required materials by tender or tender) the value of the fine due to the Irbid Electricity Company imposed by the Regulatory Authority of the Energy Sector as a result of the company's failure to comply with the required periods in executing the specified subscriber transactions Treatment is the delay of the supplier in the supply of material or materials necessary in the implementation of transactions subscribers.

## **Tendering Instructions**

1. The Tender shall be made in one copy of the accompanying form; however, all blanks and schedules shall be filled up in ink, and signed without alteration to the form of tender. If any such alteration were made, or if these Instructions were not fully complied with, the tender may be rejected. The tenderer; however, is at liberty to add any further details that he may deem desirable and, in the event of his so doing, shall print or type such details and annex the added matter to the tender submitted by him. Such additional details shall not be binding upon the purchaser unless they shall be subsequently incorporated in the contract.
2. One copy of the tender, and its accompanying documents, filled up as directed, together with the drawings, catalogs, and relevant documents called for, must be enclosed in a secure envelope endorsed (Tender for Contract) No. **(57/2022)** but bearing no other mark from which the identity of the tenderer can be ascertained.
3. All correspondences in connection with this tender and all matters accompanying the tender that are relevant to its examination shall be in English language and expressed in metric units.
4. The tender is to be held open for acceptance or rejection for a validity period of **(120) days** from the time fixed for opening the tenders.
5. Tenders received prior to the time fixed for opening of tenders will be securely kept, unopened. Tenders received after that time will be rejected. The purchaser bears no responsibility for premature opening of tenders not properly addressed or identified.
6. Tenders may be withdrawn by formal request received in writing from the tenderer prior to the time fixed for opening. If for any reason the tender should be withdrawn after the time fixed for opening and before expiry of the said validity period, the purchaser has the right to retain the full value of the tender bond.
7. The successful tenderer shall abide by the commercial and professional regulations as required by the Ministry of Industry & Trade, Engineering Association and other relevant Institutions in Jordan.
8. Tenderer attention is drawn to the action of customs officers in the discharge of their duties. Whereby air parcels are frequently opened in their own interests and in order to preserve the confidential nature of the tender price, tenderer are urged to pay attention to the:
  - a. To dispatch the completed tender document and any covering letter only by Air Mail which should be endorsed and labeled in the manner laid down in paragraph 10 of the Instructions to Tendering.
  - b. Technical literature and the like may reasonably be sent by Air Parcel or Air Freight but since this would then be separated from the actual Tender, each parcel should contain specific evidence identifying the Tender to which the contents refer.
  - c. The purchaser will not consider late or incompletely delivered tenders or literature supporting tenders due to the action of any customs officer.
9. In the event that the intending signatory does not manufacture one or more of the main sections of equipment and materials, then the tender submitted should give evidence to show that all the obligations imposed by the documents on the intending signatory have been fully understood and accepted, where applicable, by the manufacturer(s) to whom it would be intended to sub-contract one or more of the main sections of the equipment and materials.

10. For overseas transport of the contractor and his Sub-contractors, suppliers and manufactures must give priority to Jordan shipping national lines, and to Arab shipping companies and their subsidiaries for the shipping of goods, materials provided such companies ships call at the port of export. The contractor shall also give priority to the Royal Jordanian Airlines for air freight shipment and transport of personnel.
11. Tenderer must submit country of origin and name of manufacturer for the offered goods.
12. The foreign bidders who participate in this tender must submit their bids through a registered local agent or through their registered office in Jordan.
13. For all manufacturers from inside Jordan it is quite essential that they have JQM for their products and the purchaser will have the right to accept or reject their offer if they did not submit the JQM certificate with their offer.
14. If samples were not re-claimed by the tenderer within 60 days from date of order all samples shall remain the property of the purchaser.
15. The purchaser will not be responsible for, nor to pay for, any expenses or losses which may be incurred by a tenderer in the preparation of his tender.
16. If the tenderer has any doubt about the meaning of any portion of the General Conditions, Specifications, Drawings, he shall clarify such doubts before submitting his tender, or in case of any further information can be obtained by an application in writing to the director general.
17. Tenderer are particularly directed that the amount entered on the form of tender shall be a fixed price for performing the contract strictly in accordance with the bound document, and shall be the sum total of all the amounts printed into and entered by the tenderer upon the schedule of prices.
18. **Tender price shall include all incidental and contingent expenses.**
19. The tender shall be accompanied by a tender bond in the form of a Bank Guarantee valid for **at least 120 days** from the time fixed for closing date of tender, or certified check in favor of and payable to the purchaser for **a sum of.....as** a guarantee of good faith. This bond is to be issued by any approved bank in Jordan. The bond will be returned to the unsuccessful tenderer within 120 days from the time fixed for opening the tenders or at such earlier time as a tender shall have been accepted by the purchaser. In the case of the successful tenderer, the bond will, subject to the conditions of contract, be returned as soon as a formal contract agreement and a performance bond have been entered into.
20. The successful tenderer has to submit a performance bond equal to (10) percent of the total amount of the order within (30) days from date of receipt of the order. Any delay will be subject to delay penalty. If the successful tenderer fails for any reason to submit the required performance bond within (30) days, the purchaser will confiscate the bid bond and the awarding letter will be cancelled too.
21. If the successful tenderer fails for any reason to submit the required performance bond within (30) days, the purchaser has the complete right to reserve the value of materials supplied, and payment will not release till the successful tenderer submit the required performance bond.

And the bid bond will not return to the tenderer unless the performance bond shall submit to the purchaser according to tender conditions.

22. The performance bond should be valid for a period expiring at least one year after receipt of the last consignment in IDECO warehouse.
23. The tenderer shall state in his tender the name or names of the sureties, insurance company, or bank proposed for guaranteeing the performance of the contract.
24. Prices are highly recommended to be on the basis of C&F IDECO STORES. However, C&F AQABA port or Amman customs are also accepted.
25. The tenderer may state the tender price in Jordanian Dinars. If, however, a portion of the tenderer's expenditure under the contract is expected to be made in countries other than Jordan he may state a corresponding foreign currency portion of the tender price in the currencies of those other countries.
26. Stamp duty and award fees are payable on Jordanian contracts according to Jordanian laws and, after the placing of a contract, it is the contractor's responsibility to purchase legal stamps to the requisite amount depending on the contract value.
27. If after receipt of tenders, the purchaser finds any difference between prices shown on the form of tender in writing and in numerals, then the price shown in writing shall be considered correct by the purchaser and the tenderer. If any discrepancies are found between the total in the price schedule and the total obtained by adding the products of each quantity and its particular rate then, whether the price shown on the form of tender in numerals or in writing corresponds or not, the total obtained by adding the products of the quantities and their particular rates shall be considered by the purchaser and the tenderer as the tender price.
28. Tender revaluation will be consistent with the terms and conditions set forth in the tender document. In addition to the tender price adjusted to correct arithmetical errors, other relevant factors such as the time of completion of delivery or construction, operating costs where applicable, or the efficiency and compatibility of the equipment, the availability of service and spare parts, and reliability of construction methods proposed will be taken into consideration, to the extent and in the manner specified in the tender documents, in determining the evaluated tender most advantageous to the purchaser. For comparison of all tenders, the currency or currencies of the tender price for each tender will be valued in terms of Jordanian Dinars. The rates of exchange to be used in such valuation will be the selling rates published by the central bank of Jordan and applicable to similar transactions, on the day tenders are opened unless there should be a change in the value of the currencies before the award is made. In the latter case, the exchange rates prevailing at the time of the decision to notify the award to the successful tenderer may be used.
- 29. The purchaser does not bind himself to accept the lowest or any tender, nor to assign any reason for the rejection of any tender, nor to purchase the whole of the equipment and materials specified. The purchaser has the right to purchase part of the tender, even if it is only one item from the schedule of rates and prices.**
30. The tenderer shall submit with his tender in order of the relevant clauses, a statement of any departures from specifications, or he can fill in the related schedule attached herewith. Notwithstanding any description, drawings, or literature which may be submitted, all details other than those in the statement of departures shall be assumed to be in accordance with the specification.
31. The successful tenderer has to submit a performance bond equal to (10) percent of the total amount of the order within (30) days from date of receipt of the order. Any delay will be subject

to delay penalty. If the successful tenderer fails for any reason to submit the required performance bond within (30) days, the purchaser will confiscate the bid bond and the awarding letter will be cancelled too.

- 32.** Although IEC standards for workmanship, equipment and materials, have been selected in this specification as a basis of reference, standards and specifications of other countries and recommendations of other international standard organizations will be acceptable provided that they are substantially equivalent to the designated standards and provided further that the tenderer submits for approval detailed specification which he proposes to use.
- 33.** References to brand names or catalog numbers, if any, in this specification have been made only for that equipment for which it has been determined that a degree of standardization is necessary to maintain certain essential features. In certain instances, such references have also been made for purpose of convenience to specify the requirements. In either case offers of alternative goods which have similar characteristics and provide performance and quality at least equal to those specified are acceptable.
- 34.** Where compliance with a specific standard specification is called for the standard specification used shall be that in force at the time of tender.

## **General Requirements Standards and Regulations**

- The following general requirements will apply, in so far as they may be applicable, to material to be supplied under this particular contract.

### **1. Design and Construction:**

In complying with the requirements of the specification both with respect to arrangement and detail, design is to conform to the best current engineering practice. Each of the several parts of the material is to be of the maker's standard design provided that this design is in general accordance with the specification.

The essence of design should be simplicity and reliability in order to give long continuous service with high economy and low maintenance cost. Particular attention should be paid to internal and external access in order to facilitate inspection, cleaning and maintenance. The design dimensions and materials of all parts are to be such that they will not suffer damage as a result of stresses under the most severe conditions. Fully detailed specifications of the several parts of the material are to be submitted describing particularly the materials to be used. The materials used in the construction of the material are to be of the highest quality and selected particularly to meet the duties required of them. Mechanisms are to be constructed to avoid sticking due to rust or corrosion. Workmanship and general finish are to be of the highest class throughout. All similar parts of the material are to be interchangeable.

All equipment is to operate without undue vibration and with the least possible amount of noise and is not to cause a nuisance. All equipment is to be designed to minimize the risk of fire and any damage, which may be caused in the event of fire.

The equipment is also to be designed to prevent ingress of all vermin, accidental contact with live parts and to minimize the ingress of dust and dirt. The use of materials, which may be liable to attack by termites or other insects, is to be avoided.

### **2. Compliance with Standards:**

Although the standards for workmanship, material, and equipment have been selected in these specifications as a basis of reference, standards and specifications of the other bank member countries and recommendations of standards international organizations will be acceptable provided they are substantially equivalent to the designated standards and provided furthermore that the contractor submits for approval detailed specifications which he proposes to use. Reference to brand names or catalog numbers if any in these specifications have been made only for that equipment for which it has been determined that a degree of standardization is necessary to maintain certain essential features. And in certain cases such references have also been made for purposes of convenience to specify the requirements, in either case offers of alternative goods, which have similar characteristics and provide performance and quality at least equal to those specified are acceptable. If the contractor offers materials, equipment, design calculations or tests, which conform to standards other than those specified, full details of the differences between the proposed standards and that specified in so far as they affect the design or purpose of the equipment, are to be supplied by the contractor if called upon to do so by the engineer, where required by the engineer for approval purposes, the contractor shall supply, without charge, duplicate copies of the proposed standards with English translations of the relevant portions. The contractor shall have available in his place of business (or in his supplier's works) the relevant copies of standards or codes used for the use of the Engineer.

### **3. Statutory Regulations**

The materials, equipment and instruments forming part of this contract are to comply in all respect with any relevant local statutory regulations, by laws & orders currently in force.

### **4. Language**

English language shall be used in all documents contained in the tender and in all correspondence between the contractor and engineer. Whenever anything is required under the terms of the contract to be written marked, printed or engraved, the English language shall be used and duplicated in Arabic except where otherwise provided in this specification.

### **5. Correspondences**

All correspondences on matters arising out of the contract shall be addressed by the contractor to Engineer and not directly to but copied to the purchaser.

### **7. Units of Measurement**

In all correspondence, in all technical schedules, on all drawings and for all instrument scales, SI units of measurement are to be employed. On drawings where IEC or other units have been used it will be in order if the equivalent SI measurement is suitably marked in addition.

### **8. Contractor's Responsibilities**

Unless stated specifically to the contrary in the tender with full supporting explanations, the contractor will be deemed to have concurred as a practical manufacturer with the design and layout of the works as being sufficient to ensure reliability and safety in operation, freedom from undue stresses and satisfactory performance in all other essentials as a working material.

### **9. Compliance with Specification**

Notwithstanding any descriptions, drawings or illustrations which may have been submitted with the tender, all details other than those shown on the schedule of departures will be deemed to be in accordance with the specification and the standard specification and codes referred to therein.

No departures from the specification except those shown on the schedule of departures and approved by the purchaser are to be made without the written approval of the Engineer.

### **10. Drawings and catalogues**

The Tenderer must submit with his offer all the specification indicating rating, weights, and dimension and time current characteristics of the offered materials.

Before the work is put in hand, dimensioned drawings and diagrams showing all details of the material, and materials to be used are to be submitted to the engineer for approval.

No wiring or connection diagrams shall be submitted for approval unless prior approval has been obtained for schematic diagrams, which are to include control and protection schematics showing the facilities being provided and the working of the schemes.

The drawings are to be submitted in quadruplicate and as soon as possible after the commencement date of the contract, and in any case in sufficient time to permit modifications to be made, if such deemed necessary by the Engineer without delay in the delivery of the contract work. The drawings submitted are to be modified as necessary if requested by the Engineer and resubmitted for final approval. If the contractor requires urgent approval of any drawing to avoid delay in the delivery of the contract works, he is to advise the Engineer accordingly when submitting the drawing. One copy of each drawing and diagram shall be sent direct to the purchaser. It is to be understood, however, that approval of the drawings will not exonerate the contractor from any responsibility in connection with the work. After all items of material have been manufactured and accepted three 35 mm negatives of each drawing previously approved is to be provided together with one reproducible on gauge polyester base film or similar and two prints on heavy gauge white paper from such drawings as may be required to show the detail and arrangement of the material as made. All drawings submitted by the contractor or by any sub-contractor are to have the following particulars in the lower

right hand corner in addition to the contractor's name: **IRBID DISTRICT ELECTRICITY COMPANY, CONTRACT NUMBER (57/2022).**

## **11. Program of work**

Within one month of acceptance of the tender, the contractor is to forward to the engineer four copies of chart detailing the material manufacture and delivery Program for the complete contract work for his comment or approval. Copies of the approved chart, as required by the engineer, are to be provided by the contractor. The chart is to indicate the various phases of work for all items of the contractor from the commencement of the contract to its final completion, e.g. design, ordering, of materials, manufacture and delivery. If at any time during the execution of the contract it is found necessary to modify the approved chart, the contractor is to inform the engineer and submit a modified chart for approval. Such approval is not to be deemed to be consent to any amendment of the completion date stated in the schedule.

## **12. Progress Report and Meetings**

### **a. Progress Reports**

At monthly intervals after approval of the Program chart, the contractor is to submit to the Engineer and the purchaser written detailed progress reports in triplicate in an approved form, indicating the stage reached in the design, ordering of material, manufacture and delivery of all components of the material. The reports should include details of any delays and the remedial action proposed. These reports are to be forwarded promptly so that on receipt by the engineer the information contained therein is not more than seven days out of date.

### **b. Meeting:**

If during the execution of the contract the Engineer considers the progress position of any section of the work to be unsatisfactory, he will be at liberty to call such meetings, either in Irbid office, or at the contractor's work, as he deems to be necessary. If required by the Engineer a responsible representative from the contractor's works is to attend such meetings. Access to the contractors and sub-contractor's works is to be granted to the engineer at all reasonable times for the purpose of ascertaining progress.

## **13. Packing**

Each item to be packed properly or protected for shipment and be capable of sustaining heavy handling during transportation from the place of manufacture to the purchasers stores in Irbid and hence to site and to be suitable for storage for a period of 6 to 12 months after to site.

Tube ends and other similar open ends are to be protected from both external damage and ingress of dirt and moisture during transit and while at purchaser's stores. Flanged pipes are to have their open ends protected by adhesive tape or jointing and then be covered with a wooden blank flange secured by service bolts. Precautions are to be taken to protect shafts and journals where they rest on wooden or other supports likely to contain moisture. At such points, wrappings impregnated with anti-rust composition or vapor phase inhibitors are to be used with sufficient strength to resist chafing and indentation due to movement which is likely to occur in transit. Protective wrappings and impregnation are to be suitable for a period of three months. In the case of ball or roller bearings installed in any items of material, precautions are to be taken to avoid indentation of the bearing races.

Metal bindings of cases are to be of corrosion resistant material position with struts or cross battens and not with wood chocks wedged in place, unless they are fastened firmly in place. All struts or cross battens are preferably to be supported by cleats fixed to the case above and below to form ledges on which the batten may rest. Cases are to be unopened after packing to prove that there is no movement of contents.



Where parts are required to be bolted to the sides of the case, large washers are to be used to distribute the pressure and the timber is to be strengthened by means of a pad.

Where practicable, all indoor items such as electric motors, switch and control gear, instruments and panels, machine components, etc., are to be cocooned or covered in polyethylene sheeting, sealed at the joints and the enclosure provided internally with a desiccator. Each crate or package is to contain a packing list in a waterproof envelope. All items of material are to be clearly marked for easy identification against the packing list. All cases, packages, etc. are to be clearly marked on the outside to indicate the total weight, to show where the weight is bearing and the correct position of the slings and are to bear an identification mark relating them to the appropriate shipping documents. Stencil marks on the outside of casings are to be indelible. The Engineer may require inspecting and approving the packing before the items are dispatched but the contractor is to be entirely responsible for ensuring that the packing is suitable for transit and such inspection will not exonerate the contractor from any loss or damage due the faulty packing.

# Inspection and Testing

## 1. **General Requirement**

The whole of the material by the contract will be subject to inspection and testing by the engineer during manufacture and on completion. The approval of the engineer or the passing of any such inspection or test will not, however; prejudice the right of the purchaser to reject the material if it fails to comply with the specification when erected or to give complete satisfaction in service. The costs of all tests and inspection shall be borne by the contractor and shall be deemed to be included in the contract price. Before any material is packed or dispatched from the main or sub-contractor's works, all tests called for are to have been successfully carried out in presence of the engineer.

Adequate notice shall be given when the material is ready for inspection or test and every facility shall be provided by the contractor and his inspection and his sub-contractors to enable the Engineer to carry out the necessary inspections and tests.

Triplicate copies of all principal test records and test certificates shall be supplied to the Engineer for all tests carried out in accordance with the provisions of the contract.

## 2. **Sub-Contractors**

Within two months of acceptance of the tenders the contractor shall forward to the engineer a list of all sub-orders placed or intended. The contractor shall submit three copies of all sub-orders or selected by the engineer for progress or inspection. One copy of all drawings referred to in the sub-order is to be submitted unless otherwise agreed by the engineer. The drawings and sub-orders submitted to the engineer will cover all major components which are subject to electrical and mechanical pressure or stress when the material is in operation and also auxiliaries and stores which will be dispatched to site direct from the sub-contractor's work. For the purpose of this clause inter-works orders are to be treated as sub-order. Sub-orders are to include a statement advising the sub-contractor that the items being order will be subject to inspection and test by the Engineer. It is important that all copies of such orders are clearly marked with the main contractor's name and the following reference:

**IRBID DISTRICT ELECTRICITY Co. CONTRACT No (57/2022).**

Sub-Contractors are to comply with all the applicable requirements of this specification. Orders issued by the sub-contractor are also to include the main contractor's reference on their sub-order in addition to the above-mentioned heading.

## 3. **Material Tests**

The contractor shall provide test pieces as required by the engineer to enable him to determine the quality of the material supplied free of charge and any cost of the tests shall be borne by the contractor. If any test pieces fail to comply with the requirements of the appropriate specifications for the material in question, the engineer may reject the whole of the material represented by that piece, the contractor's designers and metallurgists will be consulted before any material is so rejected. In the event of the engineer being furnished with the certified particulars of the tests which have been carried out for the contractor by the suppliers of the material, he may, at his own discretion, dispense with the previously mentioned tests entirely.

## 4. **Tests at Manufacture's Works**

Works tests shall include all routine, electrical, mechanical and hydraulic tests in accordance with the relevant IEC standard or other standard may be approved except where departures there from and modifications thereto are embodied in this specification. For material not covered by an IEC or British standard or specifically mentioned in this specification the tests shall be agreed with the Engineer. After satisfactory completion of the witnessed tests at the

works, the material shall be submitted for the engineer's approval preparatory to shipping. No item of material is to be dispatched to site until the Engineer has given his approval in writing.

#### **5. Test Certificates**

Triplicate sets of all principal test records test certificates and performance curves shall be supplied for all tests carried out in accordance with the provisions of this contract. These test records, certificates and performance curves shall be supplied for all tests, whether or not they have been witnessed by the engineer. The information given in such test certificates and curves shall be sufficient to identify the material or equipment to which the certificates refers and should also bear the contract reference and heading as given in clause 7.2 of this section.

#### **6. Rejection of Plant**

IF Any item of material or component which fails comply with the requirements of this specification in any respect whatsoever at any stage of manufacture, test, erection or on completion at site may be rejected by the engineer either in whole or in part as he considers necessary, and after adjustment or modification if so directed by the Engineer, the contractor shall submit the item for the item for the further inspection and / or test. In the event defects of such a nature that the requirements of this specification cannot be fulfilled by adjustment or modification shall be replaced by the contractor, at his own expense, to the entire satisfaction of the engineer.

#### **7. Maintenance**

The contractor is to guarantee the efficient and good working of the material supplied under the contract for a period of twelve months (Gregorian) from the date of delivery of the material to Irbid, in accordance with the General conditions of contract.

#### **8. Tests**

All tests meet the requirements of latest international standard mentioned in the contract or any relevant standard.

**Irbid District Electricity Co.**

**Form of Bid Bond**

**Tender No. (57/2022)**

Dear Sir,

We are pleased to inform you that we guarantee M/S.....for the amount of.....in order to allow them to submit an offer for the due performance of the undertaking and obligation as specified in their Tender for Contract No. ....This Guarantee shall remain valid for a period of one hundred twenty days from the time fixed for opening the Tenders by IRBID DISTRICT ELECTRICITY CO. LTD.

This Guarantee shall be free from any interest and will be extended or paid in cash upon your first request in any or required, without the need for natural warning or judicial proceedings and without any rights to delay, oppose, or stop payment on our part, or on the part of the Tenderer or any of his representatives whom over. This Guarantee shall be deemed valid until the submittal of a duly executed Performance Bond.

Signed.....Bank

(Surety)

**Irbid District Electricity Co. Ltd.**

**Form of Performance Bond**

**Tender No. (57/2022)**

Dear Sirs,

At the request of.....bank (the Foreign Bank) and on behalf of M/S..... Contractor's Name and Address), We..... Bank (the Local Bank) issue in your favor our irrevocable and unconditional Performance Bond No.....in the amount of .....(In word), in this connection we ..... Bank (the Local Bank) hereby consider ourselves responsible forth unconditional payment to you or to your authorized representatives of the above sum on your first written demand in whole or in part notwithstanding any objections on the part of the above named contractor and without any need for natural warning or judicial proceedings.

This Bond will expire on..... and shall be renewed automatically for a period of ..... months and for consecutive similar periods until it is returned by you to us.

**Signed .....** **Bank**  
**(Surety)**

## Technical Specifications

- The following technical Specifications and particulars are applicable for the manufacturing, testing, and supplying of the materials seen on the invitation to tender page 3, **unless otherwise is mentioned in the following special requirements section.**

### 1. Climate Conditions:

The following is applicable unless otherwise is mentioned:

1	Maximum Ambient Temperature	50 C <sup>0</sup>
2	Minimum Ambient Temperature	-10 C <sup>0</sup>
3	Design temperature	45 C <sup>0</sup>
4	Maximum daily range of air temperature	20 C <sup>0</sup>
5	Maximum Wind Pressure	420 n/m <sup>2</sup>
6	Ice Thickness	10 mm
7	Snow Falls	1-4 days – 30 cm
8	Site altitude	0-1400m ASL
9	Average annual rainfall	40cm during November–April
10	Relative humidity in the range	30 to 60%
11	Average number of thunder storms	15 days / year
12	Prevailing wind winter average daily approximately 5-8 m/s, with gust up to 30 m/s.	
13	Summer wind average afternoon 10-13 m/s, during morning generally light and variable, gust speed up to 30 m/s.	

### 2. Power System Particulars;

The plant and materials supplied shall be suitable in all respect for continuous operation in the existing system having the following data:

1	Normal Voltage	415V	11KV	33KV
2	Maximum Voltage	500V	12KV	36KV
3	No. Of phases	3	3	3
4	System frequency (Hz)	50	50	50
5	No. of wires	5	3	3
6	Fault level (MVA)	25	350	1500
7	Fault Current / Duration	*	*	25 kA / 1s
8	Earth Fault Current / Duration	*	3 kA / 3s	3 kA / 3s
9	Neutral point Earthing	Solid	Resistance	Resistance
10	Conductor arrangement	Vertical	Horizontal	Horizontal

**3. 36 kV, gray colour silicon rubber post line insulators complete with horizontal trunnion clamps suitable for conductor size (50-200) mm<sup>2</sup> end and base fittings with zinc sleeve generally to drawing (1), and the design of the clamp shall be as explain in the drawing No.1.1,1.2**

Insulators to be supplied under this tender shall be of the line post type manufactured from silicon rubber, coloured gray, to IEC 60273 or equivalent and shall have a minimum total Creepage distance (leakage distance) of 1188 mm.

The minimum cantilever failing load of the post insulators shall be 12.5 KN, and the maximum tensile failing load shall be 20 KN. The radio interference voltage (RIV) shall be as low as practically possible and in accordance with the relevant IEC standards. All metal parts of silicon rubber post line insulators shall be made of steel and hot-dipped galvanized and to include the stud threaded portion. All nuts are also to be hot-dip galvanized and the threads, which shall be cut after galvanizing, shall be protected from corrosion by greasing. The studs shall be supplied with a spring washer and a plain washer. The washers shall also be galvanized.

The horizontal trunnion clamps of the silicon rubber post line insulators shall be suitable with the conductors' size (50,150,200) mm<sup>2</sup>.

The manufacturer should give evidence about his long term experience in manufacturing of composite insulators using silicone rubber technology for the housing, at least 12 years of experience is required.

A reference list of customers and voltage level for the last five years should be submitted with the offer.

The manufacturer should be certified according to ISO 9001 AND 9002.

Type and sample test shall be carried out in accordance with the relevant IEC standards or equivalent.

The manufacturer has to submit a test certificate shows that the 5000 hour multi stress test in accordance with the relevant IEC standards has been passed successfully, also a 5 years guarantee for the good performance of the composite insulator shall be provided by the manufacturer with the offer.

The composite insulators should have good packing in order to avoid damage during transportation and storage.

The composite insulators should be marked in accordance with IEC 61466 and shows the manufacturer's name, customer name, contract number and year of manufacture.

**4. 36 kV, gray colour silicon rubber composite tension insulators complete with end and base fittings coupling shall be socket eye and ball eye 16 B with zinc sleeve generally to drawing (2), and total length (615 ±5) mm.**

The insulators should have long term mechanical and electrical behaviour, the outer housing shall be manufactured from a high quality silicon rubber material in order to have excellent hydrophobic and ultraviolet resistant properties; thickness of silicon rubber should be stated.

The rod shall be borne free and made of acid resistance fiberglass and acid attacks to prevent brittle fracture phenomena.

The interfaces of the different materials themselves of the insulators have to be selected and designed properly, the design and jointing material between the housing and the end and base fittings shall take in to account the different thermal extension coefficients of the different materials in order to seal and prevent thoroughly the moisture ingress.

The interface between housing and core should be chemically bonded; the shed design shall be with alternate shedding and of aero dynamic profile. The Creepage distance shall be not less than 1188mm.

The manufacturer should give evidence about his long term experience in manufacturing of composite insulators using silicone rubber technology for the housing, at least 12 years of experience is required.

A reference list of customers and voltage level for the last five years should be submitted with the offer.

The manufacturer should be certified according to ISO 9001 AND 9002.

Type and sample test shall be carried out in accordance with the relevant IEC standards or equivalent.

The manufacturer has to submit a test certificate shows that the 5000 hour multi stress test in accordance with the relevant IEC standards has been passed successfully, also a 5 years guarantee for the good performance of the composite insulator shall be provided by the manufacturer with the offer.

The composite insulators should have good packing in order to avoid damage during transportation and storage.

The composite insulators should be marked in accordance with IEC 61466 and shows the manufacturer's name, customer name, contract number and year of manufacture.



**5. 36 kV, gray colour silicon rubber composite tension insulators complete with end and base fittings coupling shall be socket eye and ball eye 16 B with zinc sleeve generally to drawing (3), and total length (525 ±5) mm.**

The insulators should have long term mechanical and electrical behaviour, the outer housing shall be manufactured from a high quality silicon rubber material in order to have excellent hydrophobic and ultraviolet resistant properties; thickness of silicon rubber should be stated.

The rod shall be borne free and made of acid resistance fiberglass and acid attacks to prevent brittle fracture phenomena.

The interfaces of the different materials themselves of the insulators have to be selected and designed properly, the design and jointing material between the housing and the end and base fittings shall take in to account the different thermal extension coefficients of the different materials in order to seal and prevent thoroughly the moisture ingress.

The interface between housing and core should be chemically bonded; the shed design shall be with alternate shedding and of aero dynamic profile. The Creepage distance shall be not less than **1188mm**.

The manufacturer should give evidence about his long term experience in manufacturing of composite insulators using silicone rubber technology for the housing, at least 12 years of experience is required.

A reference list of customers and voltage level for the last five years should be submitted with the offer.

The manufacturer should be certified according to ISO 9001 AND 9002.

Type and sample test shall be carried out in accordance with the relevant IEC standards or equivalent.

The manufacturer has to submit a test certificate shows that the 5000 hour multi stress test in accordance with the relevant IEC standards has been passed successfully, also a 5 years guarantee for the good performance of the composite insulator shall be provided by the manufacturer with the offer.

The composite insulators should have good packing in order to avoid damage during transportation and storage.

The composite insulators should be marked in accordance with IEC 61466 and shows the manufacturer's name, customer name, contract number and year of manufacture.

## **6. Inspection and Testing**

### **6.1 General**

All equipment is subject to inspection by the Engineer at the Manufacturer's Works. Not less than (21) days' notice of all tests shall be given to the Engineer in order that he may present if he so desires. The Supplier shall make the tests specified and any others required by the Engineer to show that the Goods comply with the Specification and with the appropriate Schedules. The tests shall be made at the Supplier's expense.

No passing of the plant or materials by the Engineer shall relieve the Supplier of his responsibility. The Supplier shall also be responsible for proper carrying out of all tests of work and of plant and material carried out or supplied by a Sub-contractor to the same extent as if the work, plant or material were carried out or supplied by the Supplier himself.

If, due to the Goods and/or component materials not complying with this Specification; further tests are necessary, the Supplier shall pay all additional costs which may be incurred in re-testing.

During the execution of the Contract, test specimens, if required by the Engineers, shall be taken from the materials for the purpose of check tests or analyses for testing and forwarded at the expense of the supplier to the Testing Authorities selected by the Engineer.

Six copies of the Supplier's records of all tests shall be given to the Engineer.

All material which is specified for tests at the Manufacturer's Works shall satisfactorily pass such test before being painted.

All instruments used for the purpose of testing shall be approved and, if required, shall be calibrated at the expense of the Supplier by such body as may be approved.

Where type tests are specified below they shall be carried out in the presence of the Engineer. Alternatively, the Supplier shall provide certificates showing that such tests have been carried out satisfactorily on apparatus similar to that being supplied.

## **6.2 Silicone Composite Insulators**

### **2.1 Design Test**

The design tests shall prove the suitability of design, materials and method of manufacturing. These tests are prescribed in IEC 61109. It has to be shown that the design of the composite insulator, which is subject of this specification, has passed all of the required tests:

2.1.1 Test on interfaces and connections of end fittings

2.1.2 Assembled core load-time test

2.1.3 Test of housing and shed materials

2.1.4 Test of core material

### **2.2 Tests**

The tests are intended to verify the main characteristic (electrical and mechanical) of a composite insulator which is defined by Creepage distance, shed inclination, shed diameter, shed spacing, arcing distance, core diameter and the method of attachment of the metal fittings.

The test procedure shall be performed by any of the following qualified and well-recognized testing laboratories: KEMA, IPH Berlin & CESI.

The electrical and mechanical tests shall be applied to those insulators which have passed the design tests. The electrical tests shall be performed with arcing devices, if they are an Integral part of the insulator type.

**Tests are classified as follows:**

- 2.2.1 Dry lightning impulse withstand voltage test, according to IEC 60383-1,2
- 2.2.2 Wet power frequency test, according to IEC 60383-1,2
- 2.2.3 Wet switching impulse withstand voltage according to IEC60383-1,2 for voltage level exceeding 245 kV
- 2.2.4 Mechanical load-line test, according to IEC61109
- 2.2.5 Radio interference voltage test according to IEC60437

### **2.3 Sample Tests**

The sample tests serve for verification of typical characteristics of the composite insulator, especially those properties, which can be influenced by deviation or tolerances of manufacturing process and material. The following tests have to be performed on insulators taken at random from the lot and performed at a number, which corresponds to the total volume:

- 2.3.1 Verification of dimensions according to IEC61109
- 2.3.2 Verification of locking system, in case of ball and socket according to IEC60120, in line with requirements of IEC60383-1,2. For Insulators with clevis and tongue the IEC60471 is to apply
- 2.3.3 Verification of the mechanical strength SML
- 2.3.4 Galvanizing Test in accordance with IEC60383-1,2

If one insulator of the tested specimen fails to comply with the sample test requirements, re-testing has to be realized according to IEC61109.

### **2.4 Routine Tests**

Each composite Insulator has to be evaluated in the following tests:

#### **2.4.1 Visual Examination**

This includes the following steps:

- Alignment of fittings according to drawing
- Uniformity of housing surface
- Flash in case of molded parts
- Sealing system

#### **2.4.2 Mechanical Routine Test**

Each insulator has to withstand at ambient temperature a tensile load corresponding to at least 50% of the specified mechanical load (SML). The procedure is in accordance to IEC61109.

### **2.5 Ageing Test**

The manufacturer has to submit a test certificate to indicate the performance of a 5000- hour ageing test, which is a multi-stress environmental test to evaluate degradation degree of polymer insulators according as the IEC61109 ANNEX C standard. Also, documentations have to be provided to indicate that the test has been passed successfully. The test procedures must be performed by one of the following testing laboratories: KEMA, IPH Berlin & CESI.

### 6.3 Standards Referred To

The insulator as well as the complete string shall meet the requirements of the latest issue of the following standards:

IEC 60060-1	High Voltage Test Techniques Part 1: General definitions and test requirements
IEC 60437	Radio interference tests on high voltage Insulators
IEC 60471	Dimensions of clevis and tongue couplings of string insulator units
IEC 60815-(1,2&3)	Selection and dimensioning of high voltage insulators intended for use in polluted condition
IEC 61109	Composite insulators for A. C. overhead lines with a nominal voltage greater than 1000 V.

### 6.4 REFERENCE:

Bidder must include with his offer a detailed list reference indicating types, quantities, and years of service of insulators he supplied as well as detailed address of buyers, particularly these buyers having same climatic conditions in the region.

### 6.5 OFFER CATALOGUES AND SAMPLES:

Each offer should be attached with catalogues with a clear drawing with dimensions and other technical specifications for each type of the offers items.

A Non-returnable sample of each type should be submitted with the offer, and any offer received without drawings and samples will be rejected during evaluation without any prior notice.

### 6.6 DRAWINGS

Drawing for approval shall be submitted in triplicate as paper print, and after having been approved, the contractor shall have submitted six further copies, one copy at least being a reproduction on tracing as specified in these specifications

The following drawings shall be submitted with the offer:

- a) General arrangement of insulators.
- b) Detail drawings of all fittings.

The following is a list of drawing to be submitted by the contractor for approval within one month from the commencement date or such other period as may be agreed with the purchaser:

- a) Drawings corresponding to all drawings submitted by the supplier with tender.
- b) Detailed drawing of insulators, fittings.
- c) Arrangements drawing with details of all accessories.

**Drawing NO. 1**

➤ **Item No.1 - 36 KV, gray color silicon rubber post line insulators complete with horizontal trunnion clamps and total length (530 ±5) mm.**

**Technical Data**

- 1. Nominal voltage system: 33 KV
- 2. Maximum voltage: 36 KV
- 5. creep age distance: 1188 mm
- 6. specified cantilever load: 12.5 KN

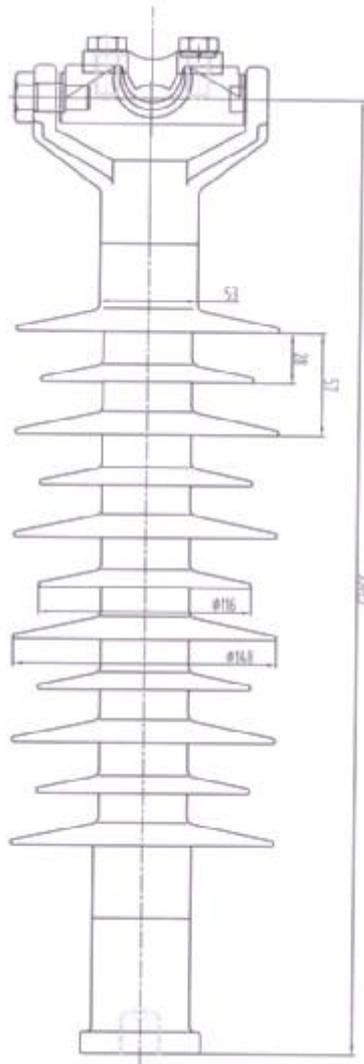

<b>IRBID DISTRICT ELECTRIC COMPANY LTD</b>		
<b>33 KV SILICON RUBBER INSULATOR</b>		
Scale	Date	Drawing no.1

**Drawing No. 1.1 clamp**

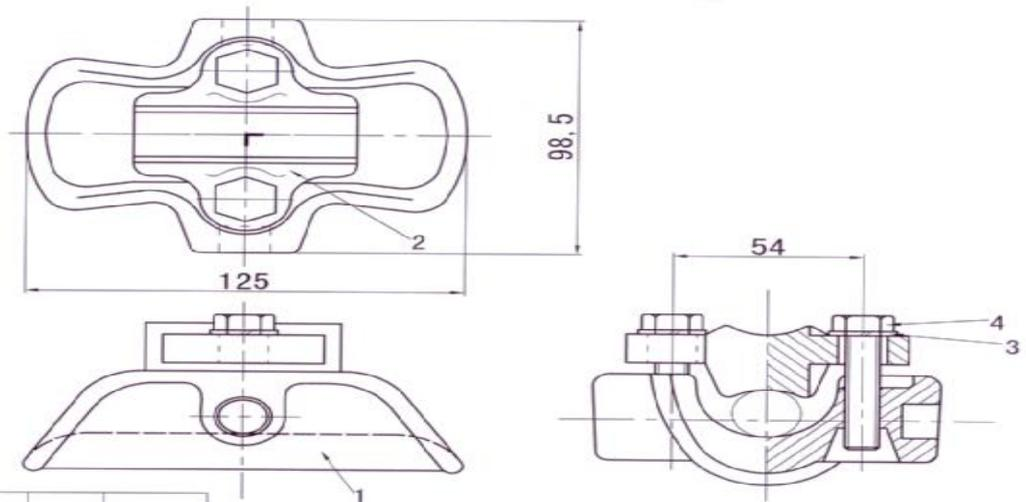

4	M12 Bolt (GB5781)		2
3	Spring Washer (GB93)		2
2	Upper Body	Al	1
1	Lower Body	Al	1
No.	Name	Material	Qty

**Drawing No. 1.2 clamp assembly**

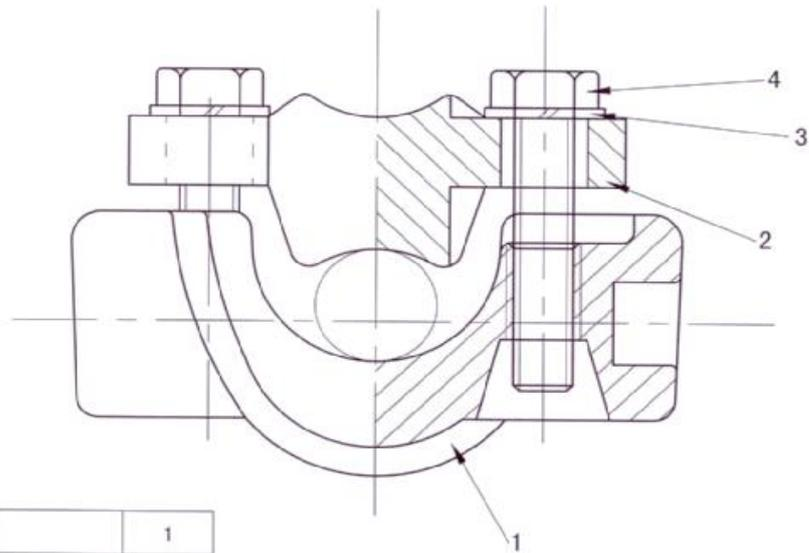

4	M12 bolt		1
3	Spring Washer		1
2	Upper Body	Al	1
1	Lower Body	Al	1

Clamp  
Assembly

**Drawing NO. 2**

- **item no. 2 - 36 KV, gray color silicon rubber composite tension insulators with total length (615 ±5) mm.**

**Technical Data**

1. Nominal voltage system: 33 KV
2. Maximum voltage: 36 KV
3. creep age distance: 1188 mm
4. Tensile strength: 80 KN

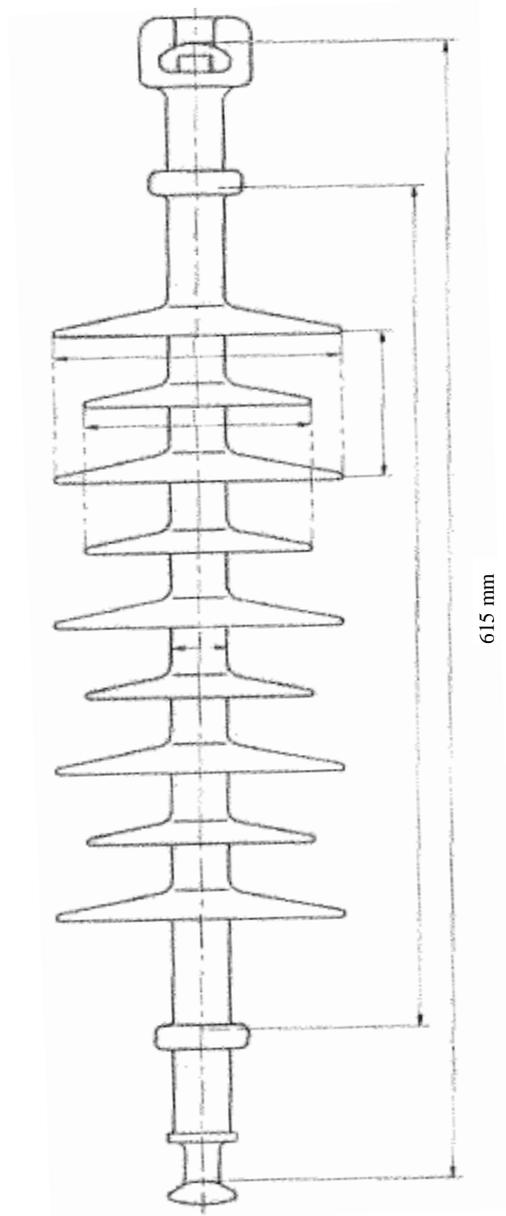

<b>IRBID DISTRICT ELECTRIC COMPANY LTD</b>		
<b>33 KV SILICON RUBBER INSULATOR</b>		
Scale	Date	Drawing no.2

**Drawing NO. 3**

- **Item no.3 - 36 KV, gray color silicon rubber composite tension insulators with total length (525 ±5) mm.**

**Technical Data**

1. Nominal voltage system: 33 KV
2. Maximum voltage: 36 KV
3. creep age distance: 1188 mm
4. Tensile strength: 80 KN

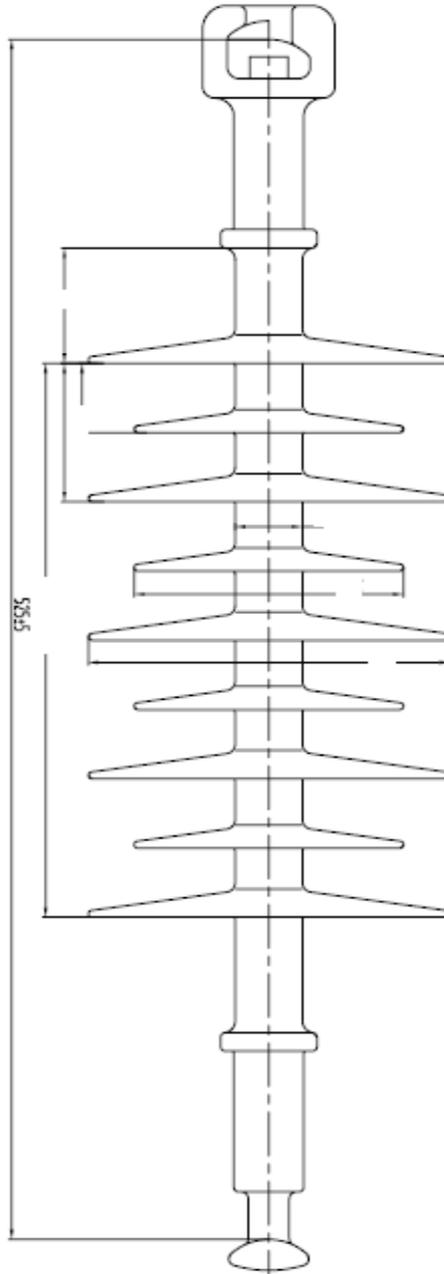

<b>IRBID DISTRICT ELECTRIC COMPANY LTD</b>		
<b>33 KV SILICON RUBBER INSULATOR</b>		
Scale	Date	Drawing no.3



**SCHEDULE (1)**  
**Technical Particulars and Guarantees**

- for 36 KV, gray color silicon rubber post line insulators complete with horizontal trunnion clamps and total length (530 ±5) mm.

This Schedule shall be completed by the Tenderer, and particulars and guarantees will be binding on the contractor.

NO	DESCRIPTION	Unit	Item (1)
1	1.1 Manufacturer		
	1.2 Type number or identification		
2	Manufacturing method		
3	3.1 Core		
	3.2 Housing including sheds		
	3.3 Sealing		
	3.4 End fittings		
	3.5 Thickness of zinc coating		
4	4.1 Comply with standard (IEC 61109 or ANSI C29.11)	(Y/N)	
	4.2 Tests reports are attached		
5	Packing and shipping		
	5.1 Net weight	Kg	
	5.2 Standard package	Kg	
	5.3 Weight of crate	Kg	
	5.4 Package volume	m <sup>3</sup>	
6	Insulator marking comply with		
7	ISO certificate is attached	(Y/N)	
8	Experience in silicone composite insulator manufacturing	Year	
9	9.1 Drawing number attached		
	9.2 Section length without hardware	mm	
	9.3 Number of sheds		
	9.4 Creepage distance	mm	
	9.5 Protected creepage distance over silicone of complete insulator (90 deg. shadow)	mm	
	9.6 Dry Arcing distance	mm	
	9.7 Outside overall diameter of unit	mm	
	9.8 Total length	mm	
	9.9 Mass of complete set with fittings	kg	

**Continue Schedule No. (1)**

<b>NO</b>	<b>DESCRIPTION</b>	<b>Unit</b>	<b>Item (1)</b>
10	<b>10.1</b> System voltage, Um	(kV)	
	<b>10.2</b> Impulse withstand voltage, 1.2/50, positive, negative.	(kV)	
	<b>10.3</b> One minute power frequency withstand voltage, 50Hz, wet.	(kV)	
	<b>10.4</b> One minute power frequency withstand voltage, 50Hz, dry.	(kV)	
	<b>10.5</b> Minimum voltage at which corona shall be visible		
	<b>10.6</b> Minimum 50HZ puncture voltage of unit.		
11	<b>11.1</b> Specified mechanical load SML, tension.	(kN)	
	<b>11.2</b> Routine test load	(kN)	
	<b>11.3</b> Maximum working load	kg	
	<b>11.4</b> Breaking cantilever strength	(kN)	
	<b>11.5</b> Tensional Load	N.m	
12	Has an Ageing Test been performed in accordance with applicable IEC standards?		
	Duration of ageing test?		
	Name and Location Testing Laboratories?		
13	End Fitting		
14	Raw material manufacturer of silicone rubber		
15	Method of moulding silicone rubber onto rod		
16	Is silicone composite insulator moulded (Y/N)?		
	If not determine the method used for assembling sheds		
17	No. of years the specified silicone composite tension insulator has been in production?		
18	Reference list		
19	Has a 5000- hour multi-stress test according to IEC61109 test been performed successfully?		

**SCHEDULE (2)**  
**TECHNICAL PARTICULARS AND GUARANTEES**

- for 36 KV, gray color silicon rubber composite tension insulators with total length (615 ±5) mm.

This Schedule shall be completed by the Tenderer, and particulars and guarantees will be binding on the contractor.

NO	DESCRIPTION	Unit	Item (2)
1	1.1 Manufacturer		
	1.2 Type number or identification		
2	Manufacturing method		
3	3.1 Core		
	3.2 Housing including sheds		
	3.3 Sealing		
	3.4 End fittings		
	3.5 Thickness of zinc coating		
4	4.1 Comply with standard (IEC 61109 or ANSI C29.11)	(Y/N)	
	4.2 Tests reports are attached		
5	Packing and shipping		
	5.1 Net weight	Kg	
	5.2 Standard package	Kg	
	5.3 Weight of crate	Kg	
	5.4 Package volume	m <sup>3</sup>	
6	Insulator marking comply with		
7	ISO certificate is attached	(Y/N)	
8	Experience in silicone composite insulator manufacturing	Year	
9	9.1 Drawing number attached		
	9.2 Section length without hardware	mm	
	9.3 Number of sheds		
	9.4 Creepage distance	mm	
	9.5 Protected creepage distance over silicone of complete insulator (90 deg. shadow)	mm	
	9.6 Dry Arcing distance	mm	
	9.7 Outside overall diameter of unit	mm	
	9.8 Total length	mm	
	9.9 Mass of complete set with fittings	kg	

**Continue Schedule (2).**

<b>NO</b>	<b>DESCRIPTION</b>	<b>Unit</b>	<b>Item (2)</b>
10	<b>10.1</b> System voltage, Um	(kV)	
	<b>10.2</b> Impulse withstand voltage, 1.2/50, positive, negative.	(kV)	
	<b>10.3</b> One minute power frequency withstand voltage, 50Hz, wet.	(kV)	
	<b>10.4</b> One minute power frequency withstand voltage, 50Hz, dry.	(kV)	
	<b>10.5</b> Minimum voltage at which corona shall be visible		
	<b>10.6</b> Minimum 50HZ puncture voltage of unit.		
11	<b>11.1</b> Specified mechanical load SML, tension.	(kN)	
	<b>11.2</b> Routine test load	(kN)	
	<b>11.3</b> Maximum working load	kg	
	<b>11.4</b> Breaking cantilever strength	(kN)	
	<b>11.5</b> Tensional Load	N.m	
12	Has an Ageing Test been performed in accordance with applicable IEC standards?		
	Duration of ageing test?		
	Name and Location Testing Laboratories?		
13	End Fitting		
14	Raw material manufacturer of silicone rubber		
15	Method of moulding silicone rubber onto rod		
16	Is silicone composite insulator moulded (Y/N)?		
	If not determine the method used for assembling sheds		
17	No. of years the specified silicone composite tension insulator has been in production?		
18	Reference list		
19	Has a 5000- hour multi-stress test according to IEC 61109 test been performed successfully?		

**SCHEDULE (3)**  
**TECHNICAL PARTICULARS AND GUARANTEES**

- for 36 KV, gray color silicon rubber composite tension insulators with total length (525 ±5) mm.

This Schedule shall be completed by the Tenderer, and particulars and guarantees will be binding on the contractor.

NO	DESCRIPTION	Unit	Item (3)
1	1.1 Manufacturer		
	1.2 Type number or identification		
2	Manufacturing method		
3	3.1 Core		
	3.2 Housing including sheds		
	3.3 Sealing		
	3.4 End fittings		
	3.5 Thickness of zinc coating		
4	4.1 Comply with standard (IEC 61109 or ANSI C29.11)	(Y/N)	
	4.2 Tests reports are attached		
5	Packing and shipping		
	5.1 Net weight	Kg	
	5.2 Standard package	Kg	
	5.3 Weight of crate	Kg	
	5.4 Package volume	m <sup>3</sup>	
6	Insulator marking comply with		
7	ISO certificate is attached	(Y/N)	
8	Experience in silicone composite insulator manufacturing	Year	
9	9.1 Drawing number attached		
	9.2 Section length without hardware	mm	
	9.3 Number of sheds		
	9.4 Creepage distance	mm	
	9.5 Protected creepage distance over silicone of complete insulator (90 deg. shadow)	mm	
	9.6 Dry Arcing distance	mm	
	9.7 Outside overall diameter of unit	mm	
	9.8 Total length	mm	
	9.9 Mass of complete set with fittings	kg	

**Continue schedule No. (3)**

<b>NO</b>	<b>DESCRIPTION</b>	<b>Unit</b>	<b>Item (3)</b>
10	<b>10.1</b> System voltage, Um	(kV)	
	<b>10.2</b> Impulse withstand voltage, 1.2/50, positive, negative.	(kV)	
	<b>10.3</b> One minute power frequency withstand voltage, 50Hz, wet.	(kV)	
	<b>10.4</b> One minute power frequency withstand voltage, 50Hz, dry.	(kV)	
	<b>10.5</b> Minimum voltage at which corona shall be visible		
	<b>10.6</b> Minimum 50HZ puncture voltage of unit.		
11	<b>11.1</b> Specified mechanical load SML, tension.	(kN)	
	<b>11.2</b> Routine test load	(kN)	
	<b>11.3</b> Maximum working load	kg	
	<b>11.4</b> Breaking cantilever strength	(kN)	
	<b>11.5</b> Tensional Load	N.m	
12	Has an Ageing Test been performed in accordance with applicable IEC standards?		
	Duration of ageing test?		
	Name and Location Testing Laboratories?		
13	End Fitting		
14	Raw material manufacturer of silicone rubber		
15	Method of moulding silicone rubber onto rod		
16	Is silicone composite insulator moulded (Y/N)?		
	If not determine the method used for assembling sheds		
17	No. of years the specified silicone composite tension insulator has been in production?		
18	Reference list		
19	Has a 5000- hour multi-stress test according to IEC61109 test been performed successfully?		

## Special Requirements

- The Below mentioned requirements shall have a precedence in all of the preceding specifications and requirements, and the tenderer is kindly requested to strictly follow.
1. The Tender Calls for: Firm Prices.
  2. The manufacturer shall print IDECO Contract No. (57/2022), and country of origin. And QR code contain the following message shall be printed on Containing box of required materials.  
IDECO Tender No. 57/2022  
Stock code xxxx-xxxx (as mentioned in table 2), Serial number, Manufacturer name  
Manufacturing date, QR-Code.
  3. Catalogues: a set of the manufacturer's catalogues shall be attached to the tender, preferred to be Arabic.
  4. The material safety data sheet (MSDS) of all equipment / materials is required to be submitted with the offer.
  5. The required materials in two shipments, and each shipment shall be inspected by two IDECO's engineers in the country of origin, and all related Inspection Costs (Visa, Air Tickets, Hotel, Accommodation, Transportation, etc.) of at least (2) IDECO representative engineers, at the manufacturer factory, shall be borne by the contractor.
  6. The contractor shall nominate third party laboratory and cost of inspection by third party as shown in Schedule No. 8, in case the attendance of IDECO engineers is not applicable due to any reason.
  7. The required materials shall be delivered in two shipments as shown in table No.3
  8. The contractor shall submit with his offer reference list (supply record) for the last five years.
  9. The contractor shall have calibrated equipment's by authorized party for inspection purposes.
  10. The purchaser has the complete right to reply on contractor's clarifications during 7 days, and during this period there is not exemption from incurred penalty for the event.
  11. After Awarding Tenders, winner tenderer will be assessment according to quality of good, delivery period, service after sale, and assessment weight will be considered in coming tenders' evaluation.
  12. Euro one certificate shall be submitted during clearance process, in case the country of origin of the required materials from Europe countries.
  13. The technical drawing approval shall be submitted during 7 days from order letter date, any delay in this period from contractor side, the delivery period will start after 7 days from order letter. (In case the contractor offered delivery period from order letter date and drawing approval).
  14. The manufacturer shall print 128 c bar code in each item as below shape, and bar code character will be submitted to manufacturer at awarding date.



## Departures from Technical Specifications

The Tenderer shall fill in the following schedule in case there are any technical deviations from the required or deviate from the standard.

### Schedule No.4

No.	Required Particular	Offered Particular
1		
2		
3		
4		
5		
6		
7		
8		
9		

Remarks:



## Program for Manufacture and Delivery Periods

Below schedule shall be completed by the tender and the periods entered shall be binding on the contractor. It is essential that the overall period for completion of the contract is adhered to and the programmer shall be formulated accordingly. **All periods entered below are to be in weeks and relate to the placing of the contract.**

### Schedule No.5

Item No.	Item	Manufacturing Period	Ex-Works Delivery	Aqaba Port Delivery
1	36 KV, gray color silicon rubber post line insulators complete with horizontal trunnion clamps suitable with conductor size (50-200) mm <sup>2</sup> end and base fittings with zinc sleeve, and total length ( 530 ±5) mm.			
2	36 KV, gray color silicon rubber composite tension insulators complete with end and base fittings coupling shall be socket eye and ball eye 16 B with zinc sleeve and total length ( 615 ±5) mm.			
3	36 KV, gray color silicon rubber composite tension insulators complete with end and base fittings coupling shall be socket eye and ball eye 16 B with zinc, and total length ( 525 ±5) mm.			

## Manufacturer and Places of Manufacture and Testing

### Schedule No.6

Item No.	Item	Manufacturer	Place of Manufacturing	Place Of testing
1	36 KV, gray color silicon rubber post line insulators complete with horizontal trunnion clamps suitable with conductor size (50-200) mm <sup>2</sup> end and base fittings with zinc sleeve, and total length ( 530 ±5) mm.			
2	36 KV, gray color silicon rubber composite tension insulators complete with end and base fittings coupling shall be socket eye and ball eye 16 B with zinc sleeve and total length ( 615 ±5) mm.			
3	36 KV, gray color silicon rubber composite tension insulators complete with end and base fittings coupling shall be socket eye and ball eye 16 B with zinc, and total length ( 525 ±5) mm.			

### Table No.3

#### Delivery period

The required materials shall be delivered in two shipments as shown in below table.

- First shipment shall be delivered during three months from order letter date.
- Second shipment shall be delivered at 15/01/2023.

No	Item	Quantity Pcs	First shipment Shall be delivered during (3) months from order letter.	Second shipment shall be delivered at 15/1/2023
1	36 KV, gray color silicon rubber post line insulators complete with horizontal trunnion clamps suitable with conductor size (50-200) mm <sup>2</sup> end and base fittings with zinc sleeve, and total length ( 530 ±5) mm.	15,000	3000	12000
2	36 KV, gray color silicon rubber composite tension insulators complete with end and base fittings coupling shall be socket eye and ball eye 16 B with zinc sleeve and total length ( 615 ±5) mm.	4,000	1000	3000
3	36 KV, gray color silicon rubber composite tension insulators complete with end and base fittings coupling shall be socket eye and ball eye 16 B with zinc, and total length ( 525 ±5) mm.	5,000	1000	4000

## Price Summary and Delivery

- The tender shall enter in the appropriate columns of this schedule the prices at which each item will be supplied. Prices shall include shipment and delivery to the selected destination seen below based on the following selected transportation obligations.
- **IDECO is not exempted from custom duties, sales taxes, import license fees and any other tariffs.**
- Delivery period shall be expressed **in weeks**, and is recommended to start from the date of the order letter, and transportation obligations shall be indicated by **putting a tick** at the proper following choice:

CFR - Aqaba Port     
  CPT- Amman Customs     
  CPT- IDECO Stores

### Schedule No.7

Item No.	Quantity (Pcs)	Material	Currency	Unit Price	Total Price
1	15,000	36 KV, gray color silicon rubber post line insulators complete with horizontal trunnion clamps suitable with conductor size (50-200) mm <sup>2</sup> end and base fittings with zinc sleeve, and total length ( 530 ±5) mm.			
2	4,000	36 KV, gray color silicon rubber composite tension insulators complete with end and base fittings coupling shall be socket eye and ball eye 16 B with zinc sleeve and total length ( 615 ±5) mm.			
3	5,000	36 KV, gray color silicon rubber composite tension insulators complete with end and base fittings coupling shall be socket eye and ball eye 16 B with zinc, and total length ( 525 ±5) mm.			
<b>Total Contract Price: (In Writing)</b>					

## Inspection Details

- In case of foreign material origin, and inspection of material is required, the bidder shall fill the following table.

### Schedule No.8

NO.	Description	Cost
1	Inspection cost in the country of origin per engineer. (If not included in the main offer).	
2	Air flight class	
3	Transportation cost during the period of inspection (Included/not included)	
4	Residential Hotel Rank	
5	Daily meals (included/Not included), Number of meals.	
Inspection cost in third party		
	Name of laboratory	
	Cost	

## Main Offer Details

- **The bidder shall fill the following table otherwise his offer may be not considered.**

### Schedule No.9

NO.	Description	
1	Value and currency of Bid Bond	
2	Payment method (open account/ LC/ Other)	
3	Offer validity	

**Tender Agreement Summary**  
**Tender No. (57/2022)**

1. Having examined the conditions of Contract, specification and schedule for the above Works, the undersigned, offer to manufacture, supply, work, test, and deliver the said works described in the specification and schedules and in accordance with the said conditions of contract, for the sum of .....or such other sum as may be ascertained in accordance with the said conditions.
2. We agree that this tender shall be held open for acceptance or rejection for the validity period of **120 days** from the date fixed for opening tenders and it shall remain binding upon us and may be accepted at any time before the expiration of that period.
3. Unless and until a formal agreement is prepared and executed, this tender, together with your written acceptance thereof, shall constitute a binding contract between us.
4. If our tender is accepted, we will deliver to Irbid District Electricity Co. Ltd. Within **(30) days** of being called upon to do so a performance bond by bank or insurance company (to be approved in either case by the purchaser) to be jointly and severally bound with us in a sum equal to **10%** of the value of the contract. The form of the performance bond will be as attached hereto. We propose the following Bank or insurance company as surety (or sureties) in this respect: -.....
5. We undertake if our tender is accepted and on receipt of your acceptance to commence and manufacture, works test, and complete for delivery **ex-works** the whole of the Works offered within (.....) weeks calculated from the date of **Order Letter Awarding**, and to deliver on the dock at (.....port) - Jordan the whole of the works offered within a further (.....) weeks, or to **IDECO stores** within a further (.....) weeks.
6. We undertake to insure the materials against all risks from the time they leave the works until they are placed on board ship. We understand that marine insurance will be effected by Irbid District Electricity and we will provide details of the materials to be shipped in good time for Irbid District Electricity to arrange for the said marine insurance.
7. A guarantee / Maintenance Period will apply to each section of the works of twelve-to- fifteen months from the date of accepting the materials at IDECO stores or in case of projects from the date of setting to work.
8. We understand that you are not bound to accept the lowest or any tender you may receive.

Dated this .....day of / / 2022.

Signature.....in the capacity of .....

Duly authorized to sign Tender for and on behalf of.....

Address..... Occupation.....